

# RESIDENTIAL WALL REPORT

## Client Information:

Xxxxx

Ph: 987-654-321

Email: xxxxx@xxxx.xxx

## Customer Information

1234 St Name, City ST 000000

Order No.0000

Date



Table of Contents	Page
Aerial Photo & Summary of Wall Areas and Lengths	2
Property Photos(North & South View)	3
Property Photos(East & West View)	4
North Elevation & Facet Table	5
South Elevation & Facet Table	6
East Elevation & Facet Table	7
West Elevation & Facet Table	8
South West Orientation	9
North East Orientation	10

**Client Information:**  
 Xxxxx

Ph: 987-654-321

Email: xxxxx@xxxx.xxx

**Customer Information**

1234 St Name, City ST 000000

# Residential Wall Report

Order No.0000

Date

## Summary of Lengths, Areas and Pitches Table

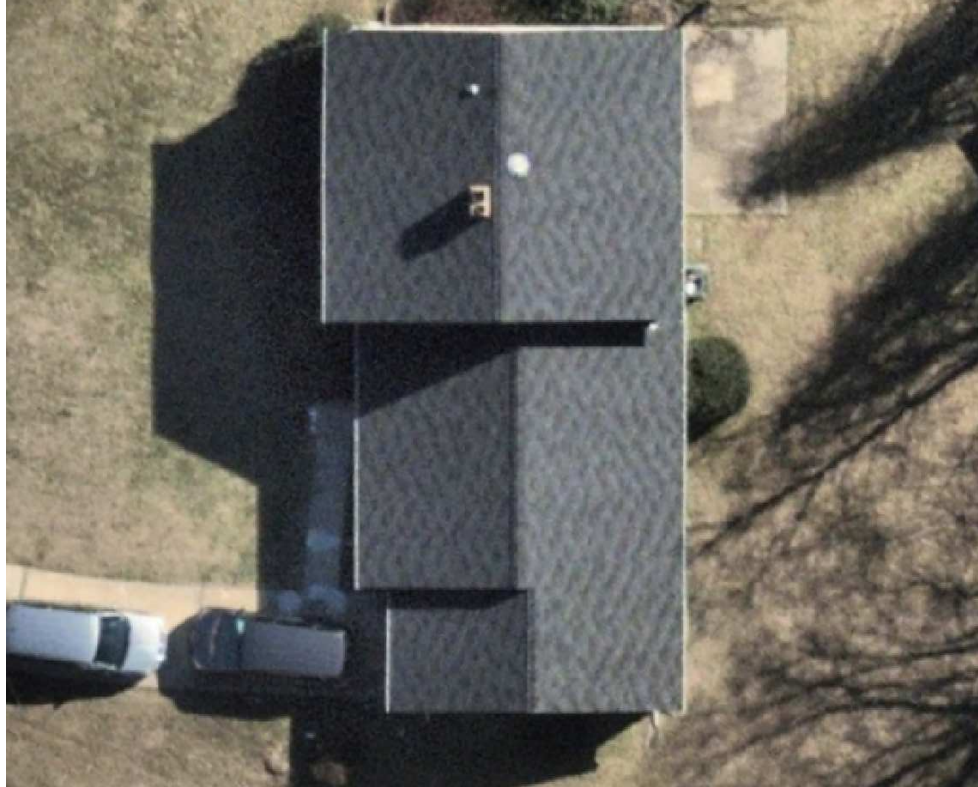

Aerial View

## Summary of Lengths, Areas and Pitches Table

Wall Areas	2701
Total Window & Door Area	433
Wall Areas with Windows & Door	3134
No. of Walls facets	12
Total Windows & Doors	21
Walls Top (ft)	272
Bottom of Walls (ft)	253
Wall Corner (ft)	118
Total Doors Perimeter (ft)	88
Total Windows Perimeter (ft)	289
Total Wall Perimeter (ft)	762

### Waste Factor Calculation for Wall Areas Only (27.01) Sq

5%	10%	12%	15%	18%	20%	25%
28.36	29.71	30.25	31.06	31.87	32.41	33.76

Client Information:  
XXXXX

Ph: 987-654-321

Email: xxxxx@xxxx.xxx

Customer Information

1234 St Name, City ST 000000

# Residential Wall Report

Order No.0000

Date

## Property Views

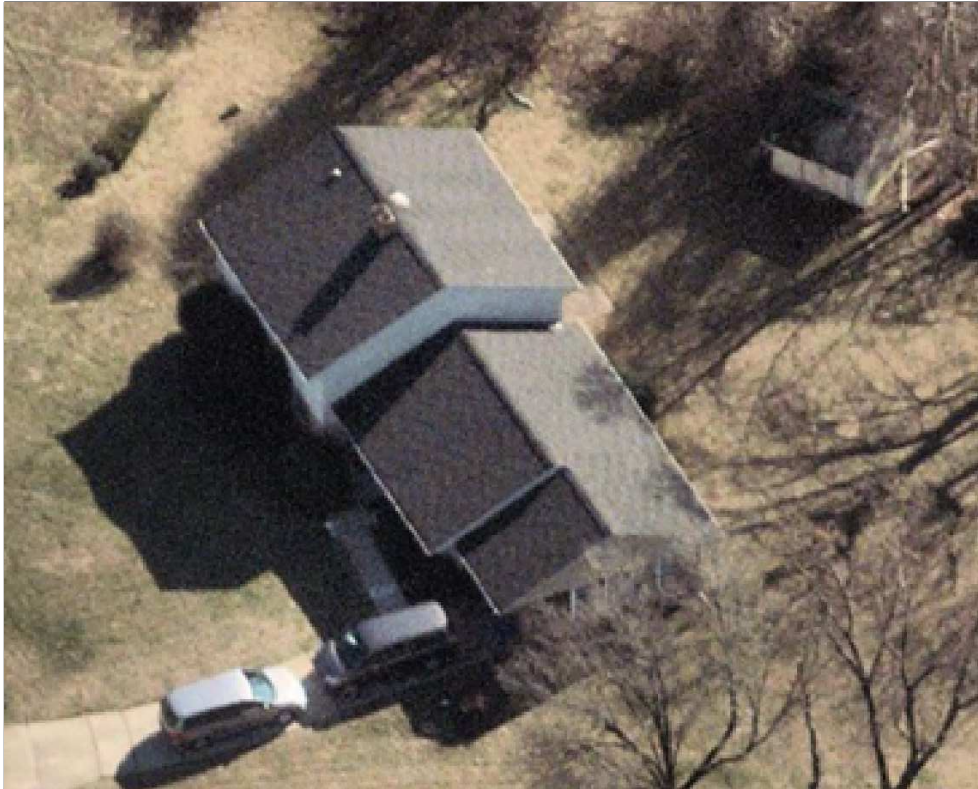

North View

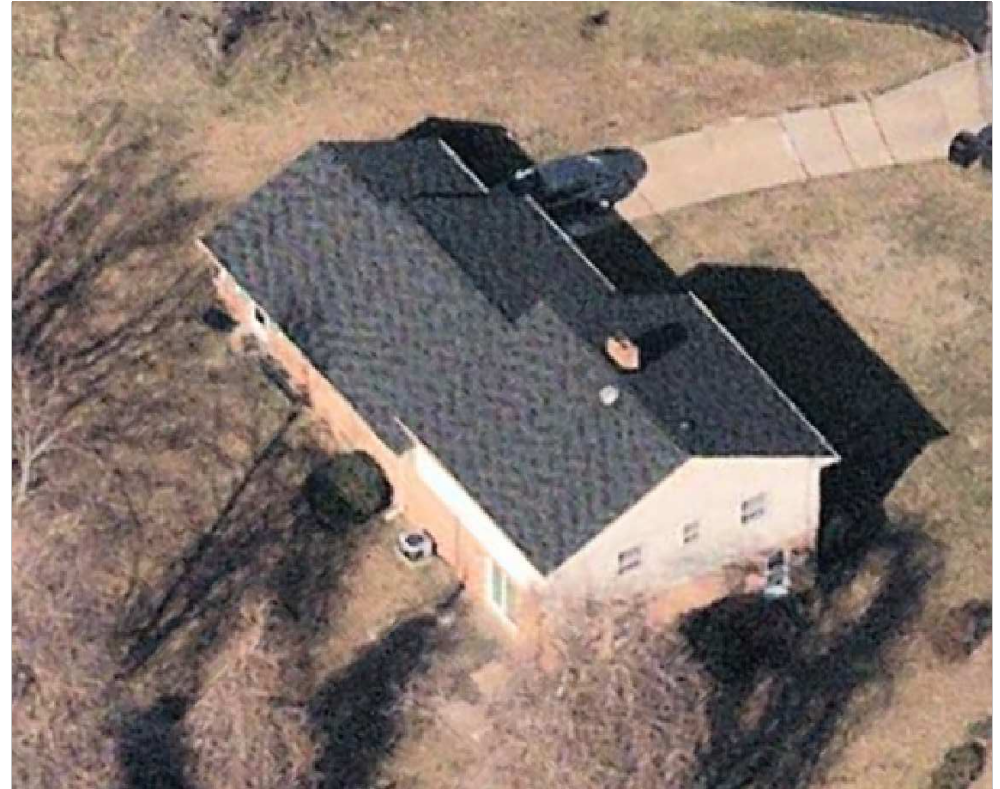

South View

**Client Information:**  
XXXXX

Ph: 987-654-321

Email: xxxxx@xxxx.xxx

**Customer Information**

1234 St Name, City ST 00000

# Residential Wall Report

Order No.0000

Date

## Property Views



East View

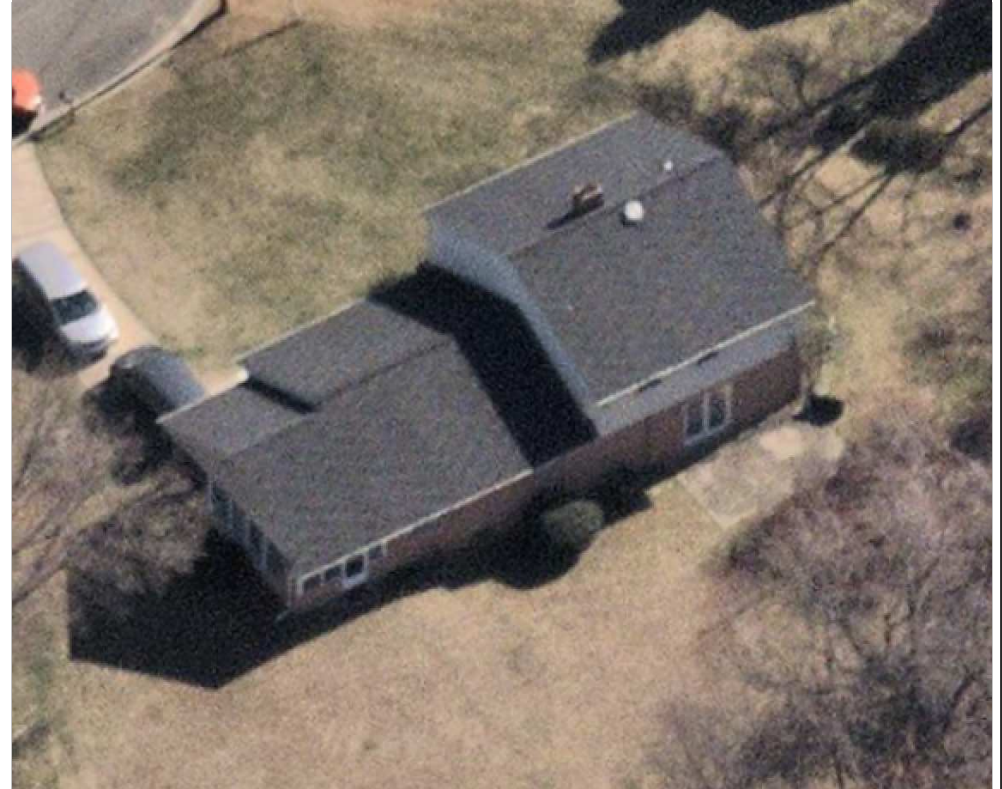

West View

Client Information:  
 XXXXX

Ph: 987-654-321

Email: xxxxx@xxxx.xxx

Customer Information

1234 St Name, City ST 000000

# Residential Wall Report

Order No.0000

Date

## North Elevation

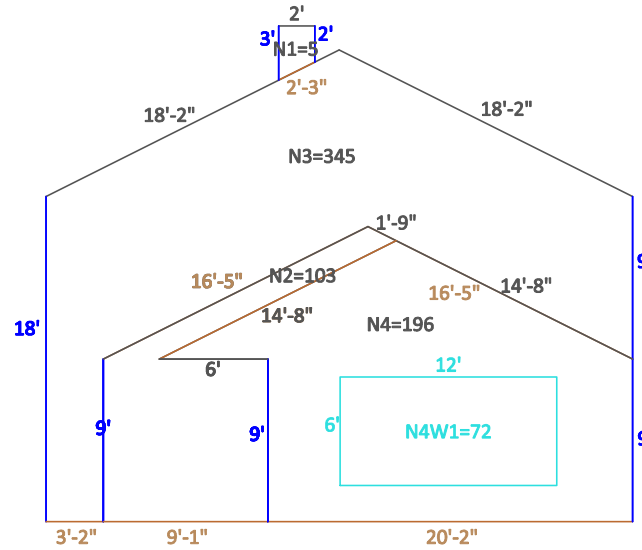

Walls			Windows			Doors		
Wall_Name	Area	Perimeter	Windows_Name	Area	Perimeter	Door_Name	Area	Perimeter
N1	5	9						
N2	103	66						
N3	345	108						
N4	196	74	N4W1	72	36			
No. of Walls = 4	Total = 649	Total = 257	No. of Windows=1	Total = 72	Total = 36			

Client Information:  
XXXXX

Ph: 987-654-321

Email: xxxxx@xxxx.xxx

Customer Information

1234 St Name, City ST 000000

# Residential Wall Report

Order No.0000

Date

## South Elevation

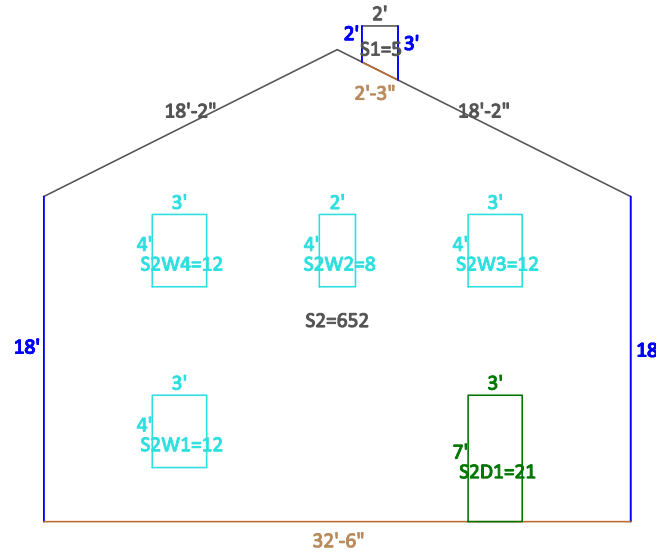

Walls			Windows			Doors		
Wall_Name	Area	Perimeter	Windows_Name	Area	Perimeter	Door_Name	Area	Perimeter
S1	5	9						
S2	652	105	S2W1	12	14	S2D1	21	20
			S2W2	8	12			
			S2W3	12	14			
			S2W4	12	14			
No. of Walls = 2	Total = 657	Total = 114	No.of Windows=4	Total = 44	Total = 54	No. of Doors = 1	Total = 21	Total = 20

Client Information:  
XXXXX

Ph: 987-654-321

Email: xxxxx@xxxx.xxx

Customer Information

1234 St Name, City ST 000000

# Residential Wall Report

Order No.0000

Date

## East Elevation

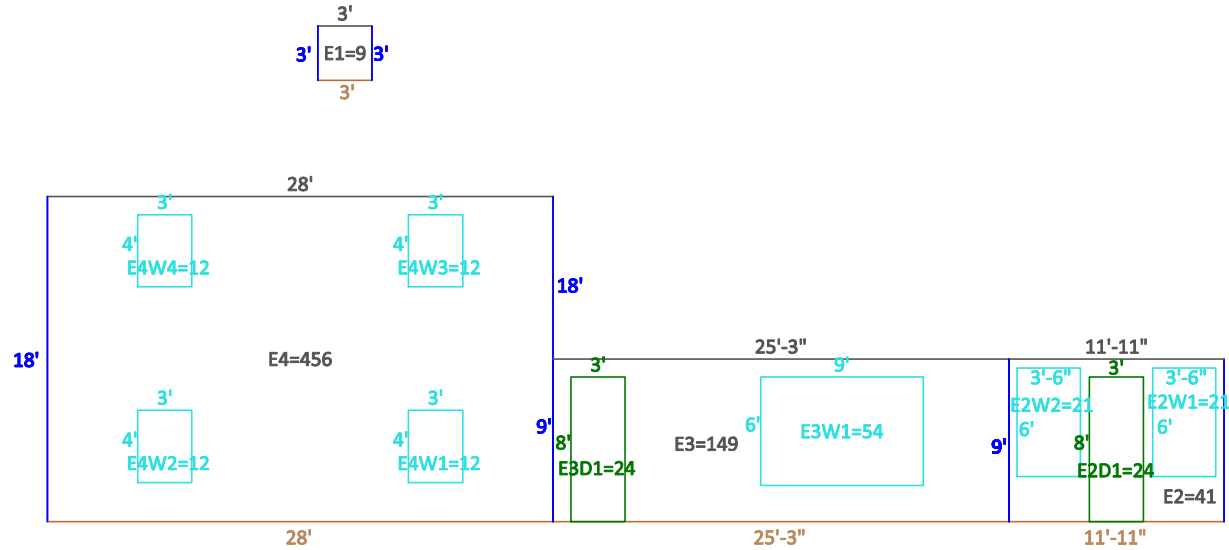

Walls			Windows			Doors		
Wall_Name	Area	Perimeter	Windows_Name	Area	Perimeter	Door_Name	Area	Perimeter
E1	9	12						
E2	41	42	E2W1	21	19	E2D1	24	22
			E2W2	21	19			
E3	149	69	E3W1	54	30	E3D1	24	22
E4	456	92	E4W1	12	14			
			E4W2	12	14			
			E4W3	12	14			
			E4W4	12	14			
No. of Walls = 4	Total = 655	Total = 215	No. of Windows = 7	Total = 144	Total = 124	No. of Doors = 2	Total = 48	Total = 44

Client Information:  
XXXXX

Ph: 987-654-321

Email: xxxxx@xxxx.xxx

Customer Information

1234 St Name, City ST 000000

# Residential Wall Report

Order No.0000

Date

## West Elevation

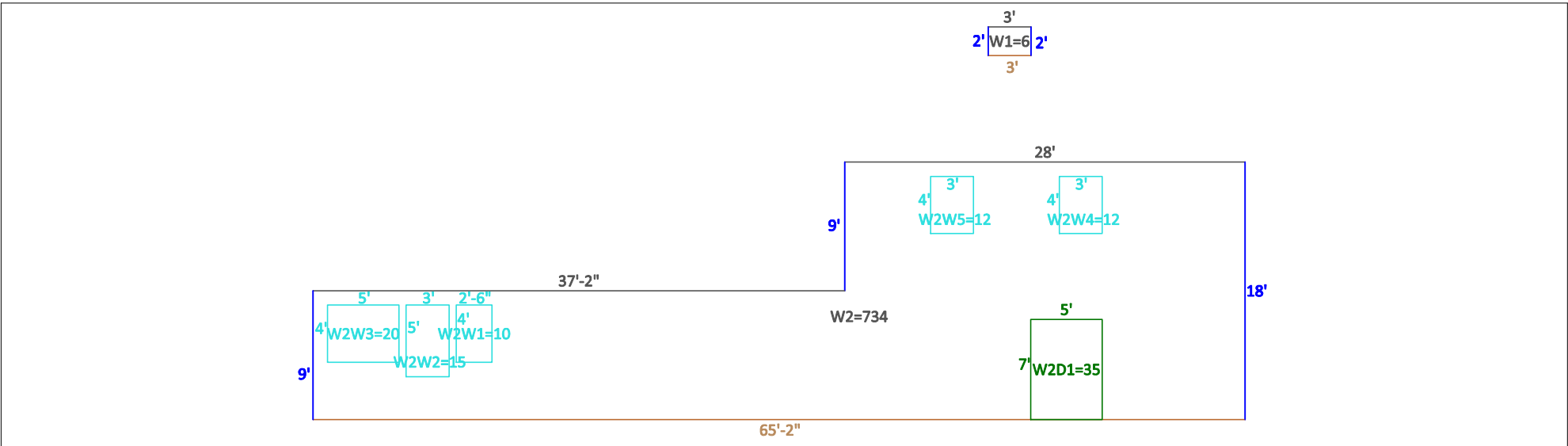

Walls			Windows			Doors		
Wall_Name	Area	Perimeter	Windows_Name	Area	Perimeter	Door_Name	Area	Perimeter
W1	6	10						
W2	734	166	W2W1	10	13	W2D1	35	24
			W2W2	15	16			
			W2W3	20	18			
			W2W4	12	14			
			W2W5	12	14			
No. of Walls = 2	Total = 740	Total = 176	No.of Windows=5	Total = 69	Total = 75	No. of Doors = 1	Total = 35	Total = 24



Client Information:  
XXXXX

Ph: 987-654-321

Email: xxxxx@xxxx.xxx

Customer Information

1234 St Name, City ST 000000

# Residential Wall Report

Order No.0000

Date

North East

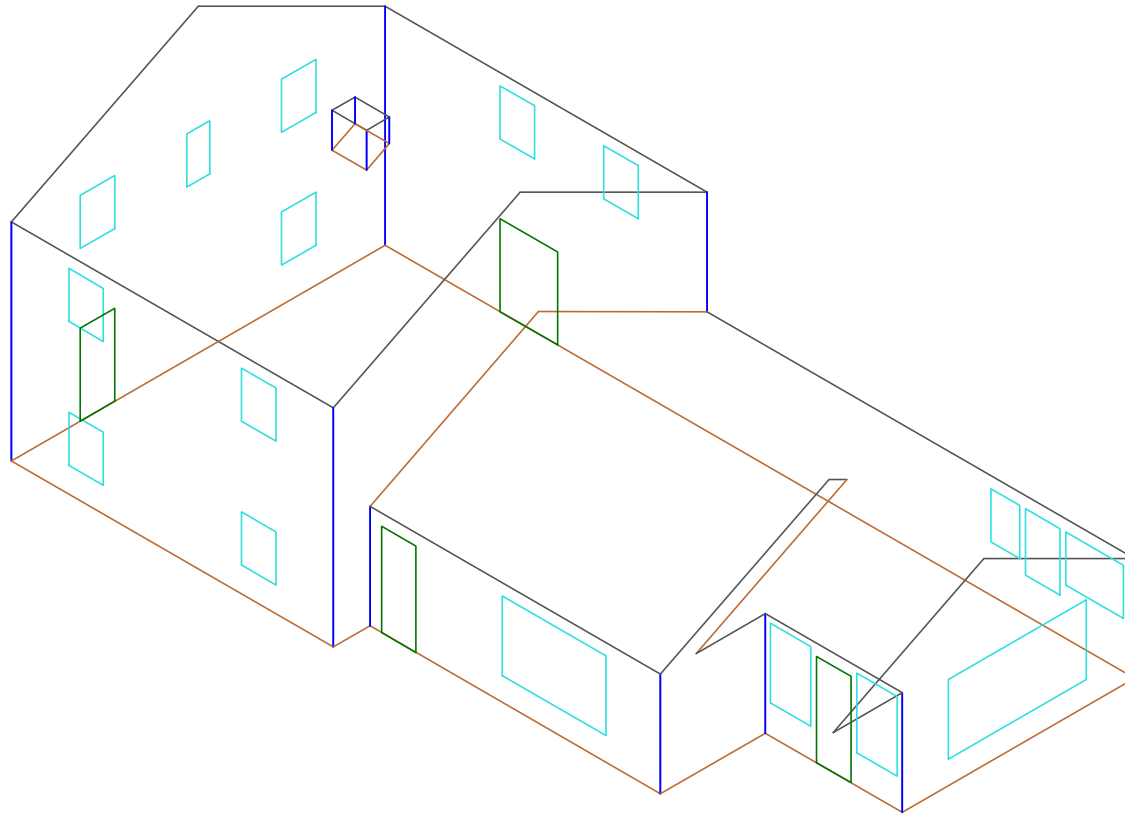

Client Information:  
XXXXX

Ph: 987-654-321

Email: xxxxx@xxxx.xxx

Customer Information

1234 St Name, City ST 000000

# Residential Wall Report

Order No.0000

Date

South West

